



Hermetic Mast Cabinet With Mounting Plate SZMH series - outdoor

Hermetic mast cabinet with mounting plate designed for outdoor installation used in optical access, telecommunication and computer networks, telecom and power engineering also with automation and control systems.



visualization of the closed hermetic mast cabinet with mounting plate
SZMH series

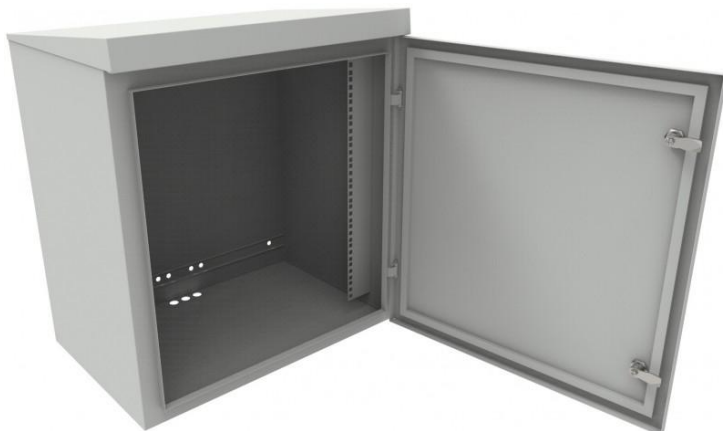

visualization of the open hermetic mast cabinet with mounting plate
SZMH series

features:

- mast rack cabinet designed for outdoor installation, used in optical access networks also with automation and control systems,
- enclosure equipped with a mounting plate allowing the installation of the necessary control equipment inside,
- the hermetic construction ensures a high protection degree against adverse weather conditions and unauthorized access,
- allows for optimal cable management and safe storage of network equipment,
- PG13.5 gland allows the installation of cables (\varnothing 8 - 12 mm),
- cabinet equipped with a single door locked with a key, key code depending on preferences can be repeatable or different,
- maximum opening angle of the front door up to 120°,
- designed for installation on a mast with a diameter of 35 - 50 mm or on a wall,
- cable entries located at the bottom of the housing,
- Magnelis® sheet is the only metallic coating certified for use in a C5 environment, which provides durability and protection against corrosion.

elements of equipment:

- PG13.5 cable glands (acc. to configuration).

equipment ordered separately:

- mast holder made of INOX steel,
- mounting plate.

standards and certificates:

- flammability class V0 acc. UL 94,
- PN-EN 60529 - ingress protection degree IP 65,
- PN-EN 62262 - impact protection degree IK 10,
- REACH Regulation No 1907/2006/EC,
- RoHS 2011/65/UE.

*The manufacturer reserves the right to make modifications and improvements to the product.
Therefore, the products shown in the illustrations and photographs may differ slightly from the actual state.*



Hermetic Mast Cabinet With Mounting Plate SZMH series - outdoor

technical specifications:

| SZMH-PM | 30 |
|---|--------------------------------------|
| dimensions [width x height x depth][mm] | 300 x 320 x 180 |
| type of cable entry | PG13.5 cable gland |
| diameter of cable entry [mm] | ø 22.5mm (2x bottom) |
| type of door | single door |
| doors construction | solid |
| removable side panels | NO |
| thermostat | YES (equipment ordered separately) |
| grounding details | doors, roof |
| mounting type | outdoor, mast, wall-mounted |
| temperature resistance [°C] | from -40 to +70 |
| ingress protection degree IP | IP 65 |
| impact protection degree IK | IK 10 |
| flammability class | V0 acc. UL 94 |
| weight [kg] | ~5 |
| material | powder painted Magnelis® sheet |
| available colors | RAL7035 |



Hermetic Mast Cabinet With Mounting Plate SZMH series - outdoor

technical drawings:

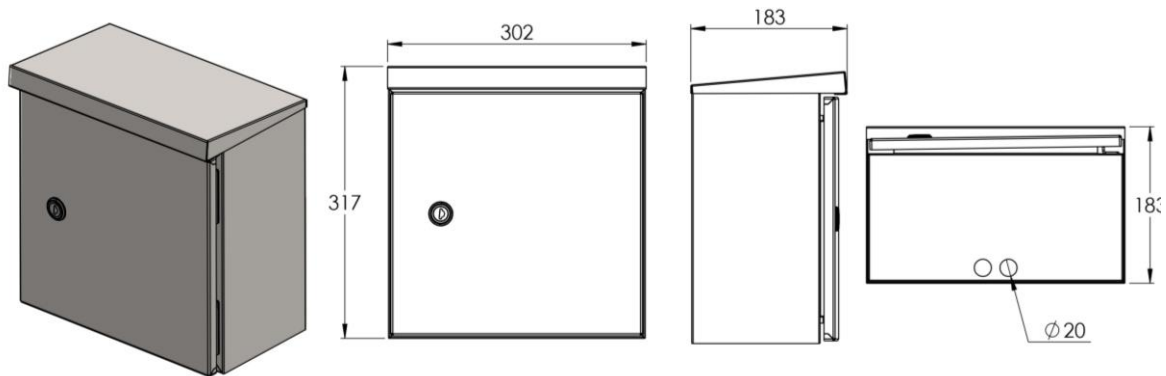

order information:

| CODE | DESCRIPTION |
|-------------------------------|--|
| SZMH-300/320/180-P-PM-S-R7035 | Hermetic mast cabinet with mounting plate, SZMH-300/310/180-P-PM, outdoor, solid doors, single door, 300x310x180mm (WxHxD), Magnelis®, structured, RAL7035 |